

Class 125 • Bolted Bonnet • OS&Y • All Iron • Flanged

G-624 Gate Valve

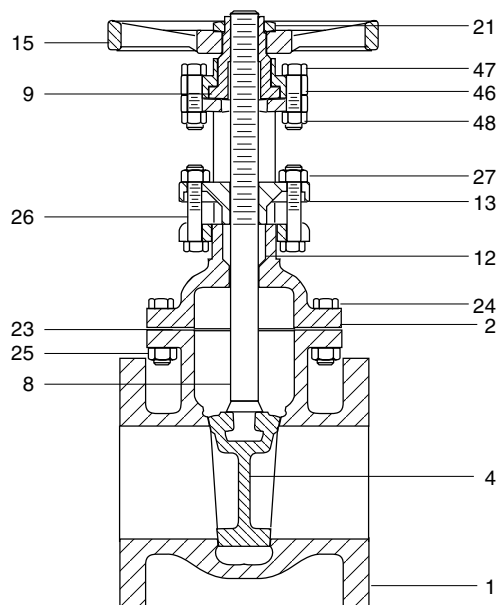

Dimensions and Weights Inches (millimeters) - Pounds (kilograms)

Valve Size	Dimensions			WT
	B	C	M	
2	14.75	8.00	7.00	33
	(375)	(203)	(178)	(15)
2 ½	16.06	8.00	7.50	47
	(408)	(203)	(191)	(21)
3	17.38	8.00	8.00	58
	(441)	(203)	(203)	(26)
4	21.44	10.00	9.00	97
	(545)	(254)	(229)	(44)
5	25.81	10.00	10.00	135
	(656)	(254)	(254)	(61)
6	30.31	12.00	10.50	162
	(770)	(305)	(267)	(73)
8	37.75	14.00	11.50	280
	(959)	(356)	(292)	(126)
10	49.41	18.00	13.00	502
	(1255)	(475)	(330)	(228)
12	56.81	18.00	14.00	670
	(1442)	(457)	(356)	(304)
14	64.38	20.00	15.00	1093
	(1635)	(508)	(381)	(497)
16	75.25	22.00	16.00	1425
	(1911)	(559)	(406)	(647)
18	82.00	22.00	17.00	1738
	(2083)	(559)	(432)	(790)
20	90.62	24.00	18.00	2085
	(2302)	(610)	(457)	(911)
24	105.28	30.00	20.00	3183
	(2674)	(762)	(508)	(1446)

Materials of Construction

No.	Description	Material	ASTM
1	Body	Cast Iron	A126 Class B
2	Bonnet	Cast Iron	A126 Class B
4	Disc	Cast Iron	A126 Class B
6	Seat Ring*	Cast Iron (12" - 24")	A126 Class B
8	Stem	Carbon Steel, Nickel-Plated	A108
9	Yoke Sleeve	Manganese Bronze	B584 C86400
12	Packing	Braided Flexible Graphite with Corrosion Inhibitor	
13	Gland	Ductile Iron (2" - 8")	A536 Gr. 65-45-12
		Carbon Steel Zinc-Plated (10" - 24")	A108
15	Handwheel	Ductile Iron	A536 Gr. 65-45-12
21	Handwheel Nut	Sintered Nickel Steel (2" - 10")	B484 Gr. 2 CL B Type II
		Ductile Iron (12" - 24")	A536 Gr. 65-45-12
23	Bonnet Gasket	Aramid Fibers with SBR Binder	
24	Bonnet Bolt	Carbon Steel	A307 Gr. B
25	Bonnet Bolt Nut	Carbon Steel	A563 Gr. A
26	Gland Bolt	Carbon Steel	A307 Gr. B
27	Gland Bolt Nut	Carbon Steel Zinc-Plated	A563 Gr. A
46	Yoke Cap	Ductile Iron	A536 Gr. 65-45-12
47	Yoke Cap Bolt	Carbon Steel	A307 Gr. B
48	Yoke Cap Bolt Nut	Carbon Steel	A563 Gr. A
55	GLD Follower*	Ductile Iron (10" - 24")	A536 Gr. 65-45-12

* Not shown
See page 5 for Pressure Temperature Ratings

Industry Standards

MSS SP-70, Type 1

